

# Water Fall

bath enclosures

## Model 70 Framed Continuous Hinge Door Installation Instructions

Installation Tools Required: Tape Measure, Masking Tape, Level, #2 Phillips Screwdriver, Drill with 1/8", 7/64" and 3/16" bits, hacksaw, pencil, clear silicone caulking. Optional: Miter Box, File and Center-Punch.

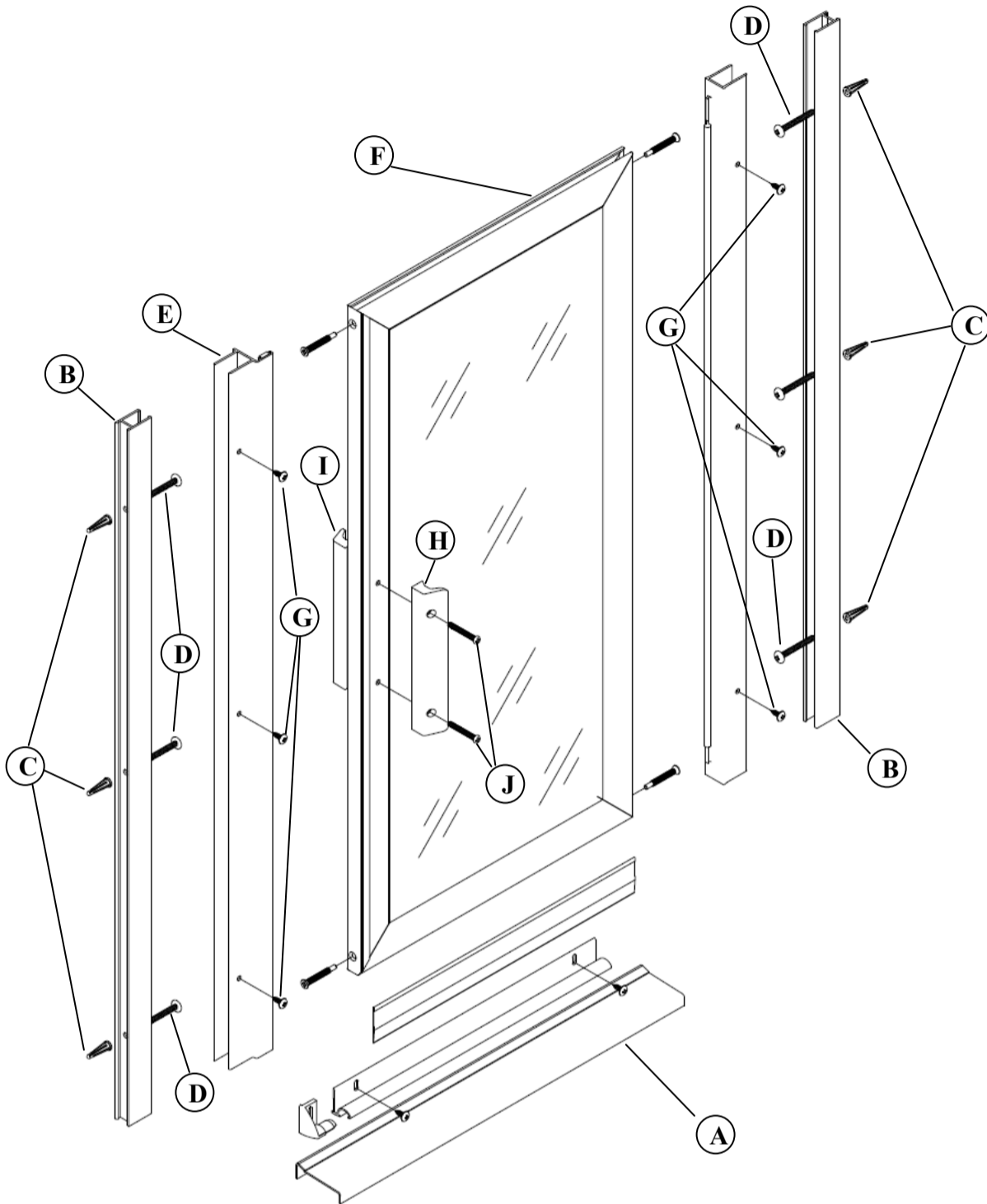

**1** The Model 70 Framed Continuous Hinge Door is reversible and may be installed hinge-right or hinge-left. Use the diagram below to determine the correct position for your installation. For maximum waterproofing the hinge jamb should always be opposite the shower head. These instructions depict a hinge-left installation.

**CAUTION:** Door must always open outward.

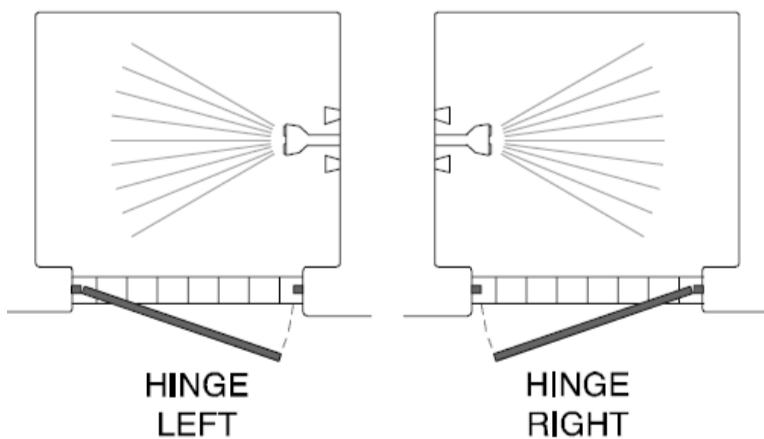

**2** **NOTE:** Obscure glass doors should be installed with the rough surface of the glass to the exterior of the unit.

**3** The Model 70 may be installed without the sloped curb, however use of the curb is recommended for proper water control on sills with little or no slope.

Measure the wall-to-wall opening at the shower sill and cut the curb to the exact length. If necessary file the ends of the curb to fit rounded corners of the enclosure. Place the curb on the sill with the **RAISED** portion to the exterior of the enclosure. Center the curb on the sill and mark its position on the sill with a pencil. Remove the curb from the sill.

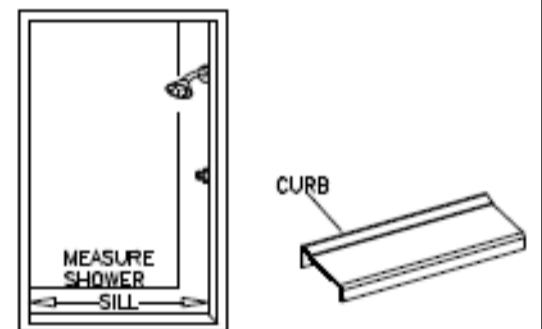

**4** Run two beads of caulk inside the pencil marks on the sill. Place the curb [A] in the exact position marked in step #2 and press it firmly into the caulking. Also caulk where the ends of the curb meet the walls. Hold curb in place with masking tape.

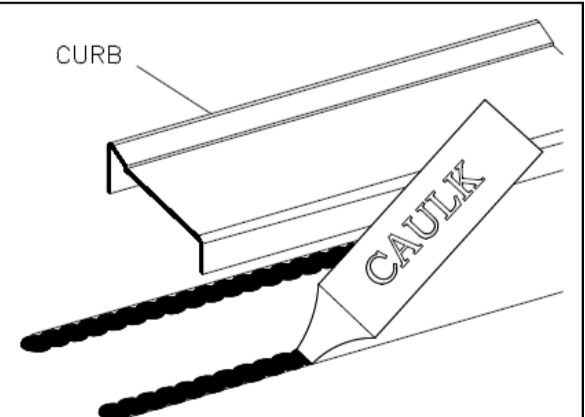

**NOTE:** Improper caulking will result in leaks.

**5** Place one of the wall jambs [B] against the wall with the bottom end 3/16" from the raised side of the curb [A]. Plumb the jamb, hold in place with masking tape and mark the hole locations on the wall. Repeat for the other wall jamb. Remove all parts and drill the walls for mounting hardware.

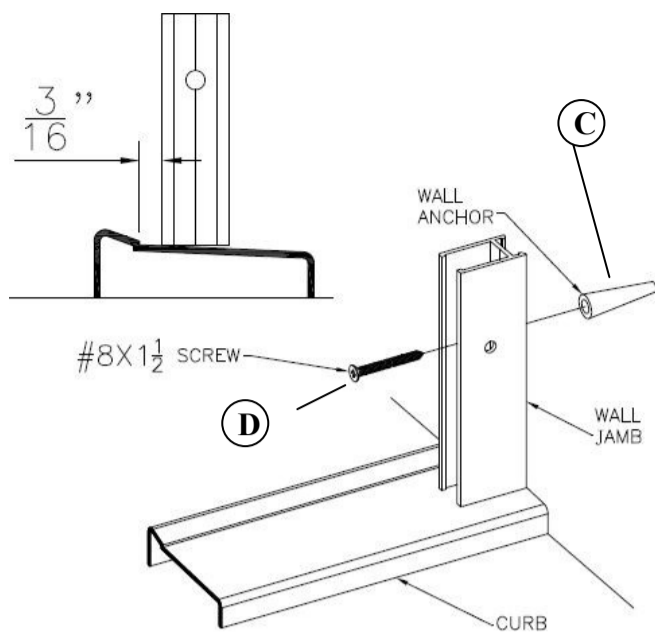

For tile or marble walls drill six 3/16" diameter holes and insert plastic wall anchors [C].

Attachments to fiberglass or acrylic units can be made in two ways. If reinforcement is built into the wall, drill six 1/8" diameter holes and install mounting screws. If walls are not reinforced drill 3/16" holes and install plastic wall anchors or Molly bolts (Molly bolts not supplied).

Replace each wall jamb and attach them with three #8 x 1 1/2" truss head screws [D].

**6** Slide the strike jamb [E] over one of the mounted wall jambs [B] with the magnet facing outward.

Measure the wall-to-wall opening at the top and at the bottom of the wall jambs and note the smaller dimension. Measure the entire width of the door panel [F] from the outside edge of the side rail to the edge of the glass on the strike side. Add 2 1/4" to the door width, subtract the total from the smallest wall-to-wall opening dimension and divide the result by 2. This should be the distance from the wall to the strike jamb at the closest point.

Plumb the strike jamb vertically and mark its location on the wall jamb with a pencil.

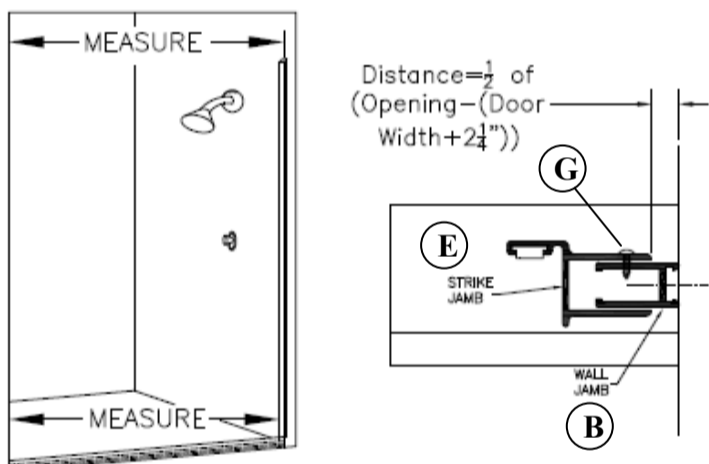

**7** Inside the enclosure, drill two 1/8" holes through the strike jamb [E] and into the wall jamb [B] 3/8" to 3/4" from the wall and approximately 1" vertically from each end of the strike jamb. Drill a third hole centered between the first two. Enlarge the three holes in the strike jamb with a 3/16" drill for clearance on the self-tapping screws. Attach the strike jamb with three #6 x 3/8" pan head screws [G].

**8** Slide the hinge jamb of the door panel assembly [F] over the mounted wall jamb [B] so the door will open outward.

Adjust the door panel assembly so there is 1/4" clearance between the strike jamb and the strike edge of the door glass in the closed position. Mark the location of the hinge jamb on the wall jamb with a pencil. Repeat the drilling instructions from Step #7 and attach the door panel assembly with three #6 x 3/8" pan head screws [G]. Repeat Step #7 for hinge jamb attachment.

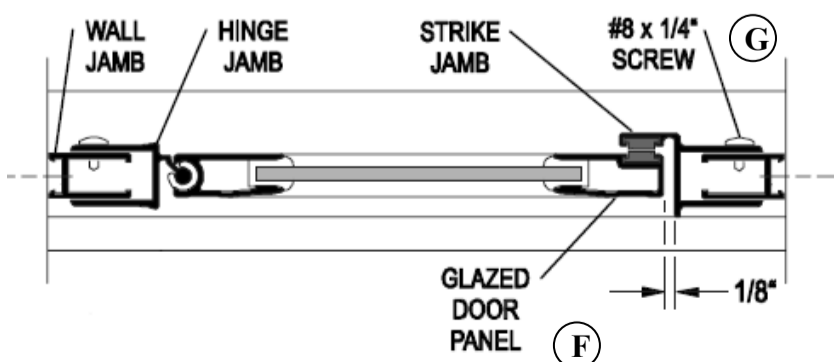

**9** Attach the interior door handle [H] and the exterior door handle [I] to the door with two #6-32 x 1 1/4" round head screws [J].

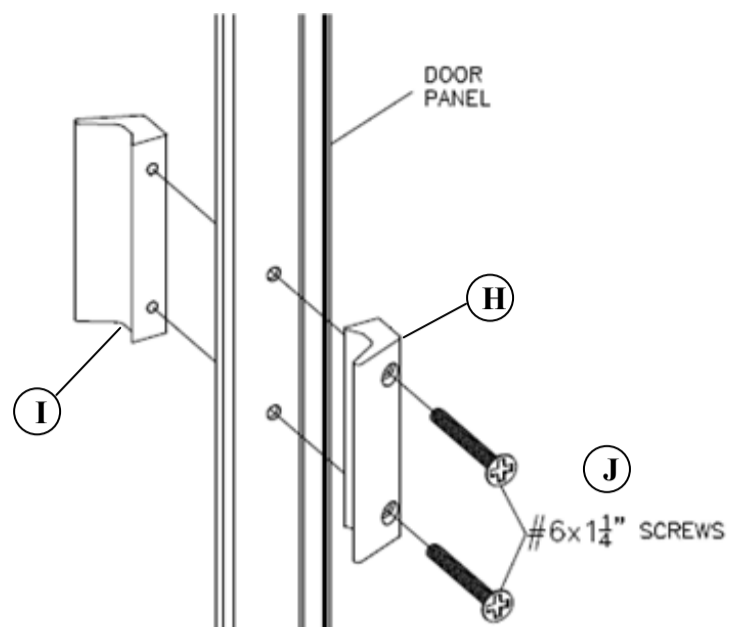

For drip rail installation refer to separate instruction sheets Adjustable Drip Installation or Standard Drip Installation.

Neatly caulk the inside perimeter of the shower curb and wall jambs. **Note:** Allow 24 hours for caulk to cure before using your shower.

Clean your new Waterfall Enclosures with a soft cloth and a non-abrasive cleaner with a neutral Ph. Do not use acid based cleaners, vinegar or scouring pads to clean your unit.